



Commissioning and performance of a phase-compensated optical link for the AWAKE experiment at CERN

D. Barrientos, J. Molendijk, A. Butterworth, H. Damerau, W. Höfle, M. Jaussi
CERN, Geneva, Switzerland



LLRF 2017
Barcelona

Introduction

The Advanced Wakefield Experiment (AWAKE) [1] aims at studying proton-driven plasma wakefield acceleration for the first time. A test facility, currently being built at CERN, uses the proton beam from the SPS machine, with a momentum of 400 GeV/c, to accelerate an electron beam to the GeV scale over 10 meters of plasma. According to simulations, this yields an accelerating gradient of about 1 GeV/m, which is more than 2 orders of magnitude larger than RF cavities currently being used.

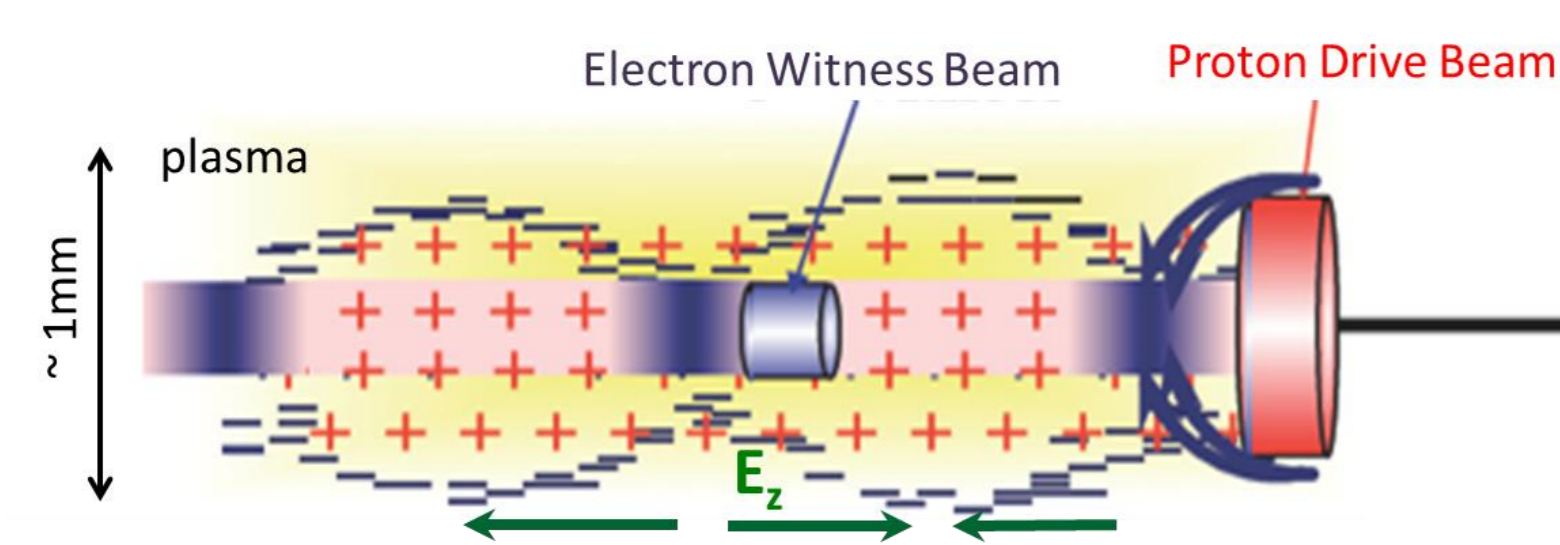

Figure 1 – Proton driven wakefield acceleration concept

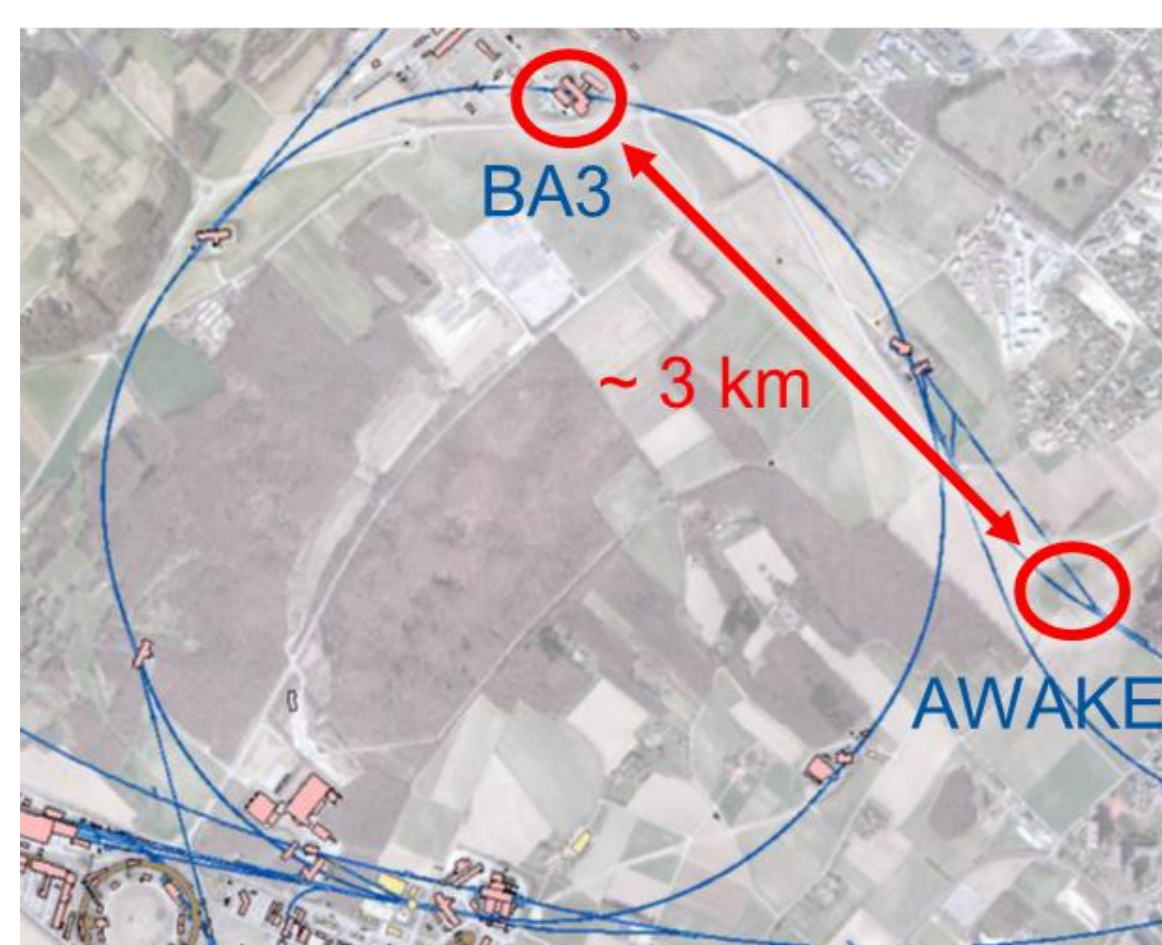

Figure 2 – SPS beam control and AWAKE laser room locations

The LLRF system for AWAKE is synchronizing the high intensity laser pulses generating the plasma, the electron and proton beams. Laser pulses and electron beam are synchronized physically at the same place and almost no drift in their reference signals is expected. However, the reference signal for the proton beam has to be transported to the SPS beam control system, about 3 km away from the location of the laser. Single-mode optical fibers used for transmitting the reference signals may introduce phase drifts due to changing environmental conditions. However, a very precise synchronization of the beams is required to get the maximum energy transfer from the proton to the electron beam and, therefore, the maximum accelerating gradient.

Proposed solution

After detailed design studies, a new electronic board was developed for the synchronization of the proton beam and laser pulses in the AWAKE experiment [2-3]. In order to stabilize the phase with a precision in the picosecond level, several considerations were taken during design phase, among which:

- Development of critical region using differential signals to avoid common-mode noise.
- Detailed study of phase noise contribution of SFP transceivers, introducing a jitter (integrated between 10 Hz and 10 MHz) lower than 150 fs.
- Long term logging setup to evaluate maximum expected drift due to seasonal changes. In the 3 km fiber setup, the maximum expected drift is below 3 ns.
- Digitization of both polarities of differential signal out of the phase detector to reach a noise floor that has proven to be in the 10 fs range.
- Use of delay lines with coarse and fine control. The former with 10 ps step size, allowing to cover a range of 10 ns. The latter with a range of 30 ps controlled by an analog signal generated by an external 18-bit DAC.
- Development of periodic calibration modes to compensate for non-linearity effects in delay lines, temperature changes in active devices and other effects.

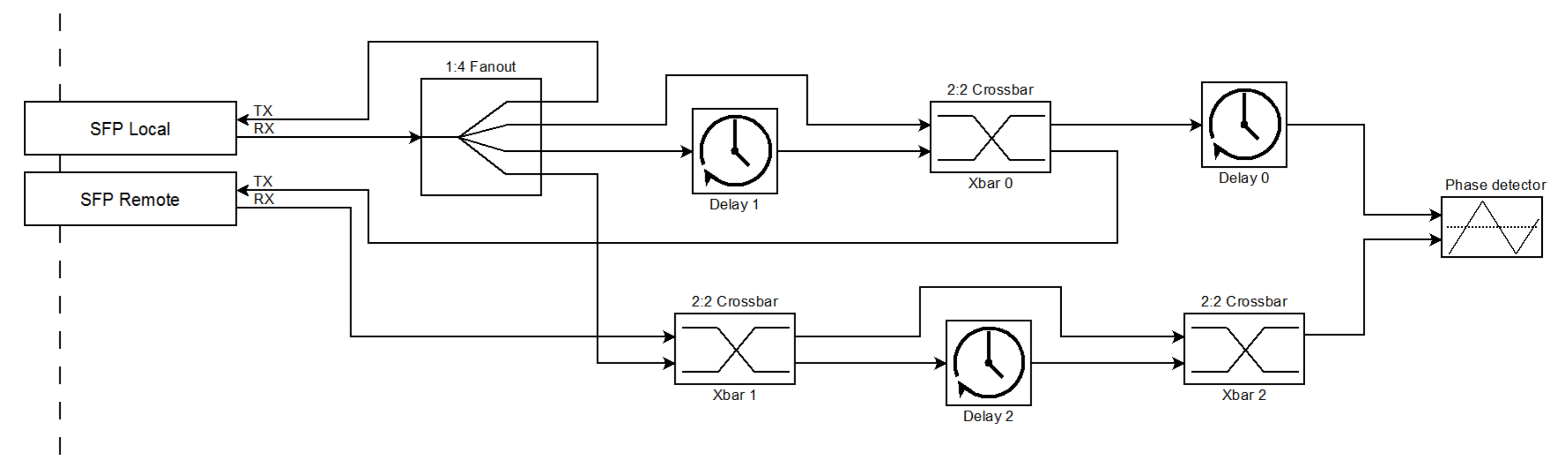

Figure 3 – Block diagram of critical region devoted to measure and compensate phase drifts over the fiber link

Hardware commissioning

Following the AWAKE schedule, the first validated prototype of the module was installed during the commissioning phase of the laser and proton beam in summer 2016. From its installation, the module has been delivering the RF reference signal used to extract the beam from the SPS machine, the common frequency between AWAKE and SPS LLRF systems and the laser repetition rate without any issue, contributing to the first physics run of AWAKE, which took place during autumn 2016.

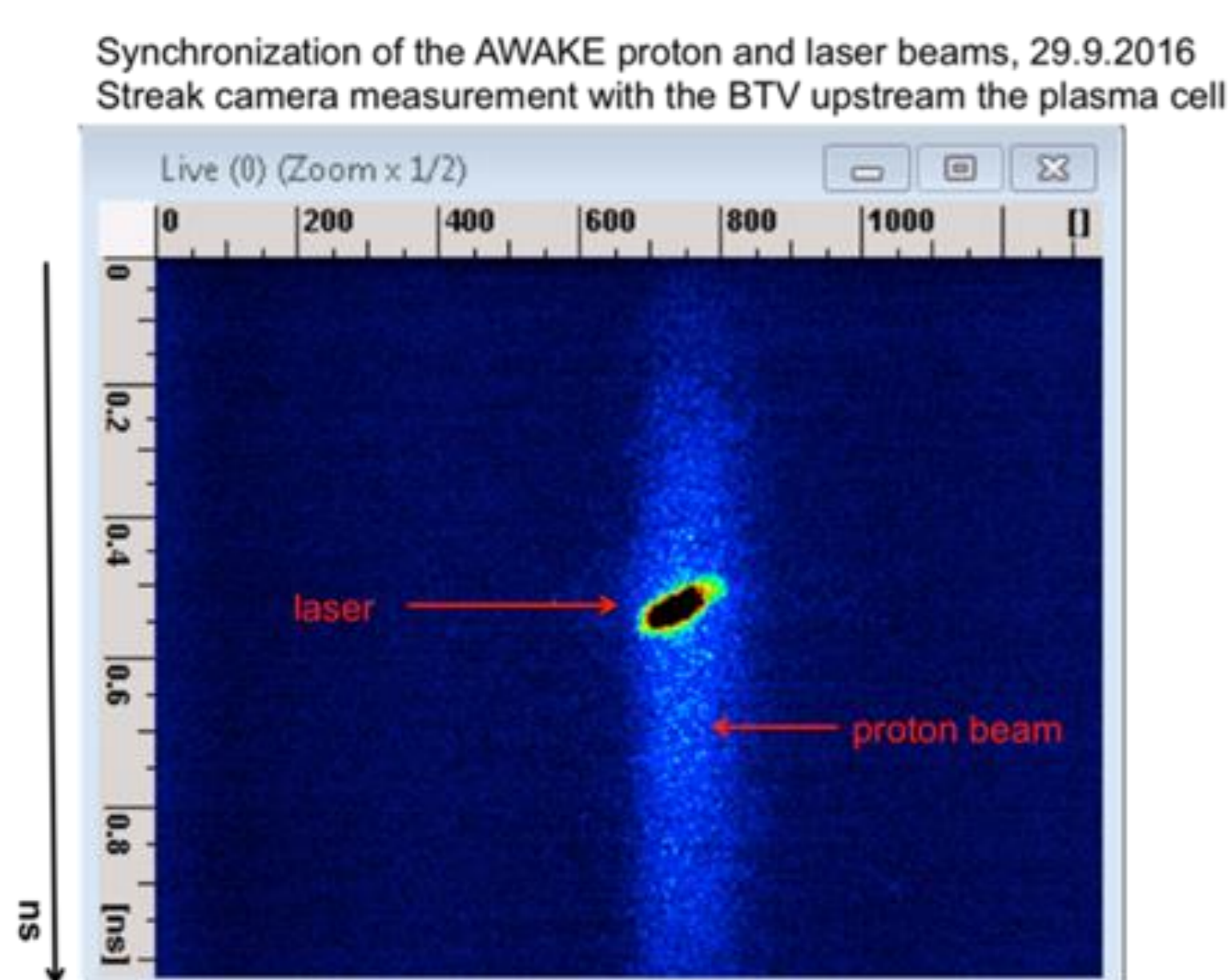

Figure 4 – First measurement of synchronized laser spot and proton beam [4]

Since the module was installed in the machine, operational data have been recorded in a centralized logging database. The analysis of these data has been used to monitor the status of the system during periods without beam in the experiment. After the physics run, the AWAKE schedule foresaw a commissioning phase for the electron beam, which is currently taking place. During this period, planned power cuts in the installation have shut down the system, which has shown very good reproducibility when recovering the previous state. No drifts in the relative position of the laser and proton beam have been recorded during the last year, therefore a successful operation is expected for the next physics run at the end of the year.

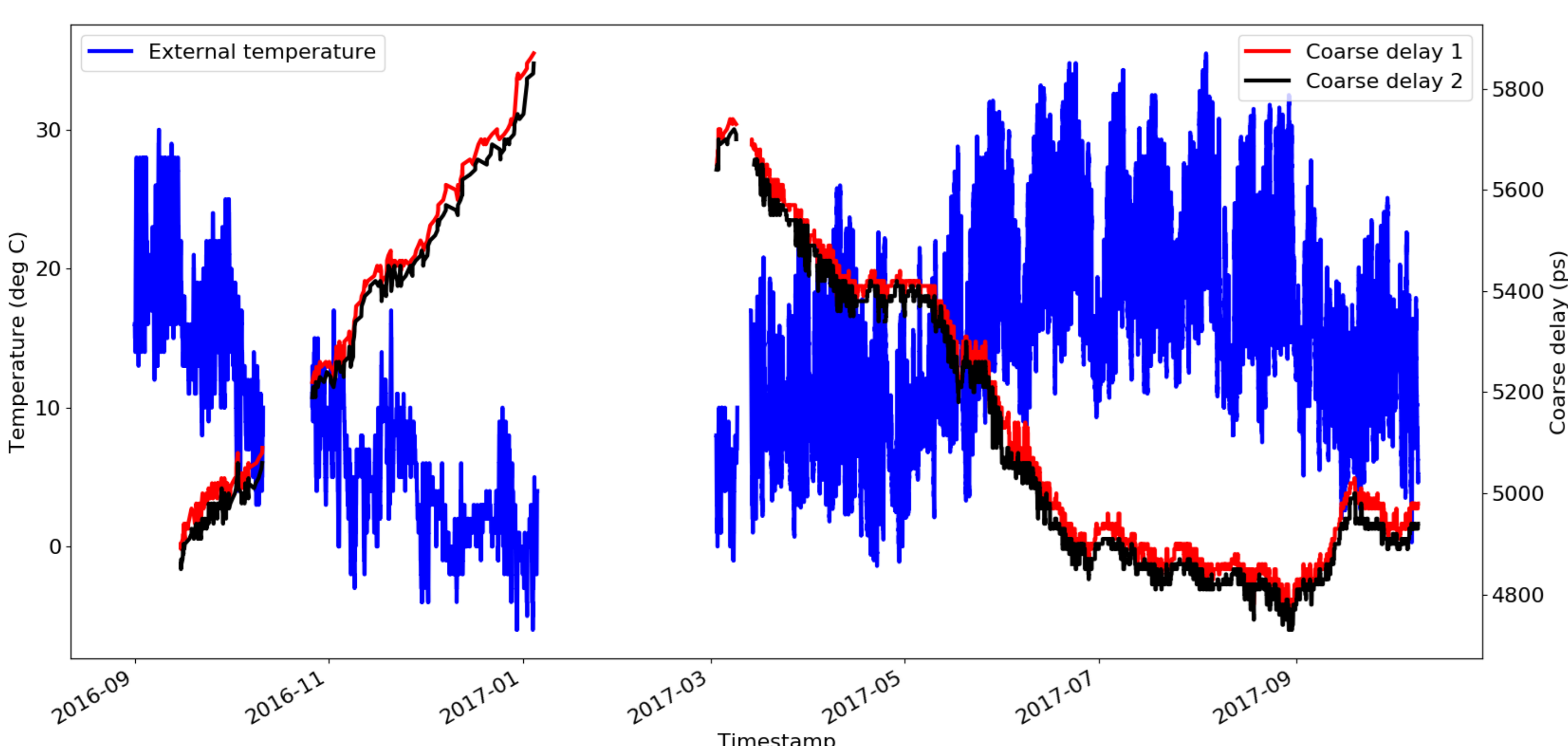

Figure 5 – External temperature and coarse delay corrections

Module performance

In order to test the performance of the module, a test bench with two optical fibers of 3 km placed in a chamber with controlled temperature has been setup. This configuration allow to access both ends of the long optical fiber and control its conditions at the same place.

A test to evaluate the added phase noise in the whole system has been performed. Firstly, recording the phase noise at the output of the low-noise signal generator used for the tests. Secondly, recording also the phase noise at the far end of the long optical fiber, after electrical conversion. The feedback loop compensating phase drifts in the fiber was active during the test. Finally, computing the jitter from the phase noise data, integrated between 10 Hz and 10 MHz, and subtracting quadratically the jitter values. The calculated added jitter is 591 fs.

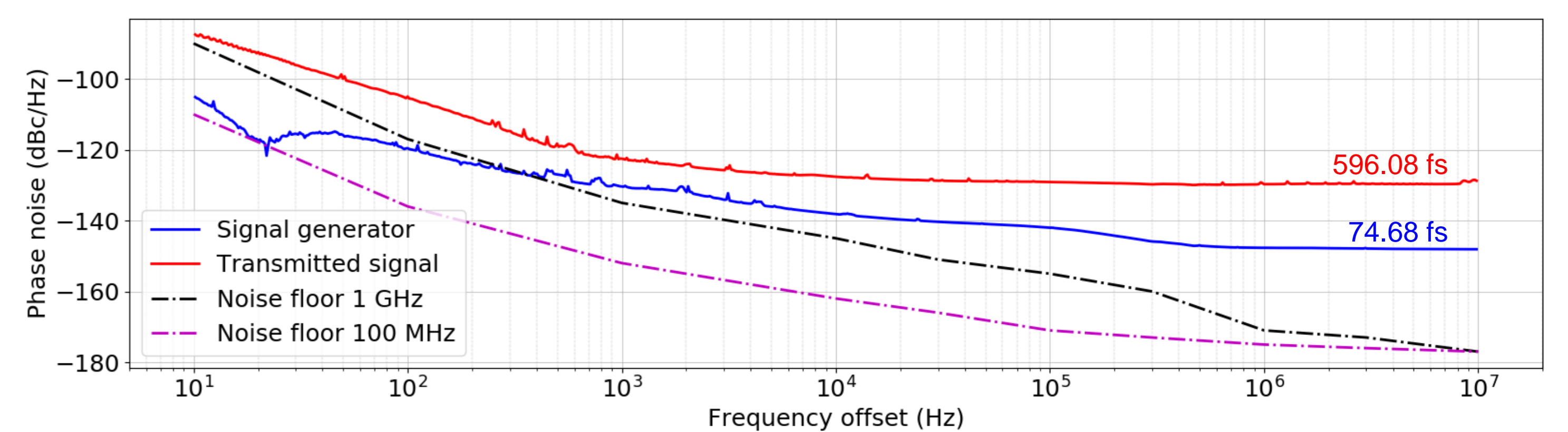

Figure 6 – Phase noise plots of signal generator and transmitted signal

Additionally, a test to measure the uncompensated phase drift when comparing signals at both ends of the long optical fiber has been carried out. An independent measurement of the phase difference has been logged using an external module. These data have been analyzed to obtain a correlation between residual phase drift and fiber temperature changes. The three tests are:

- Setup using two long optical fibers of approximately the same length. At the far end, a copy of the signal is sent back using an optical splitter.
- Setup using only one long optical fiber in two directions by means of Wavelength-Division Multiplexing (WDM) techniques and an electrical splitter at the far end.
- Previous setup with disabled feedback loop to evaluate phase drift without compensation.

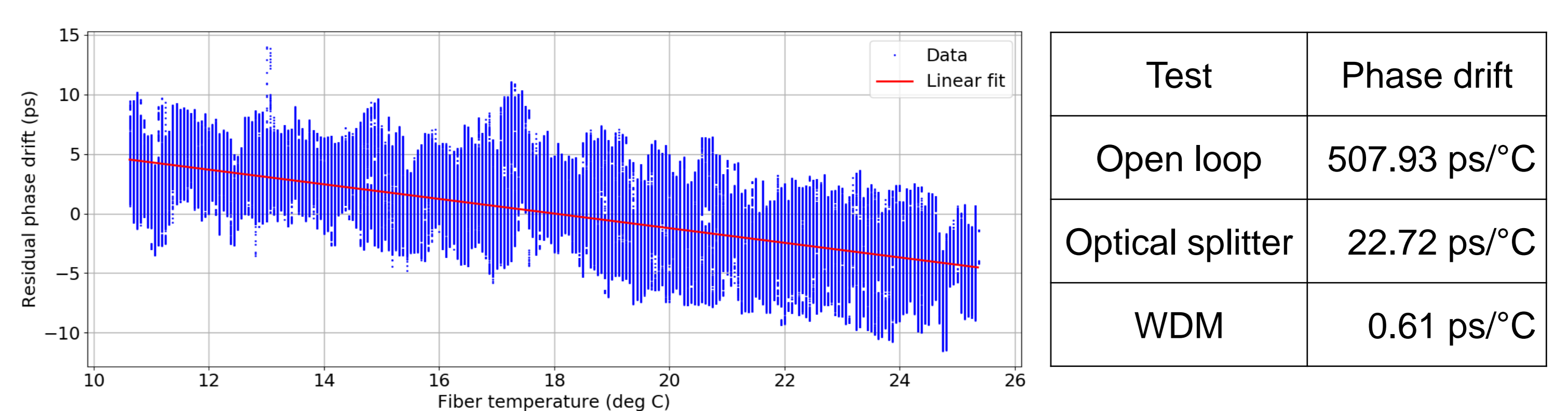

Figure 7 – Phase drift vs. fiber temperature for WDM test



Paper number: 71
Paper reference: P-64

REFERENCES

- [1] E. Gschwendtner et al., AWAKE collaboration, "AWAKE, the advanced proton driven plasma acceleration experiment at CERN", Nucl. Instrum. Meth. A 829 (2016) 76.
- [2] J. Molendijk, D. Barrientos et al., "Phase drift compensation with sub-picosecond precision over an optical link of 3 km for the AWAKE experiment". Oral presentation at LLRF 2015.
- [3] D. Barrientos, J. Molendijk, "Phase stabilization over a 3 km optical link with sub-picosecond precision for the AWAKE experiment", IEEE Trans. on Nucl. Science (2016).
- [4] J. S. Schmidt et al., "AWAKE proton beam commissioning". Proceedings of 8th International Particle Accelerator Conference (IPAC) 2017.